

## BP1002-Steel Reinforced HDPE Corrugated Pipe Couplers

### 1.0 Description

#### Available Size

- DN300mm-1000mm

#### Stiffness strength

- SN16

#### Function

- Join the Steel Reinforced HDPE Corrugated Pipe with plain ends together with rubber rings
- Welding the two couplers into pipes
- Insert the small coupler into the bigger one

#### Material

- High-density polyethylene/HDPE

#### Standard

- EN 13476-3,ASTM F2435-15

#### Features

- Resistant to compression,
- High strength
- UV light, weather, chemicals
- Ground subsidence.

#### Application

- Underground Drainage pipelines, Storm Pipe lines

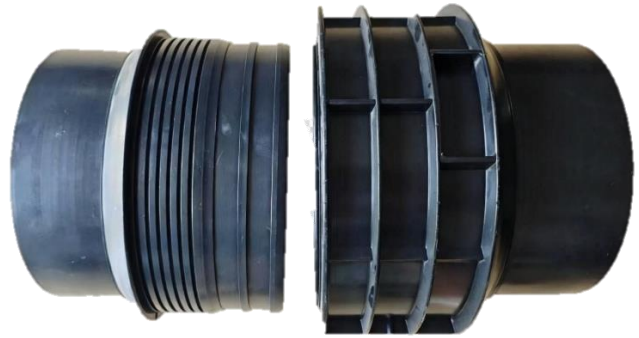

## BP1002-Steel Reinforced HDPE Corrugated Pipe Couplers

### 2.0 Technical Data

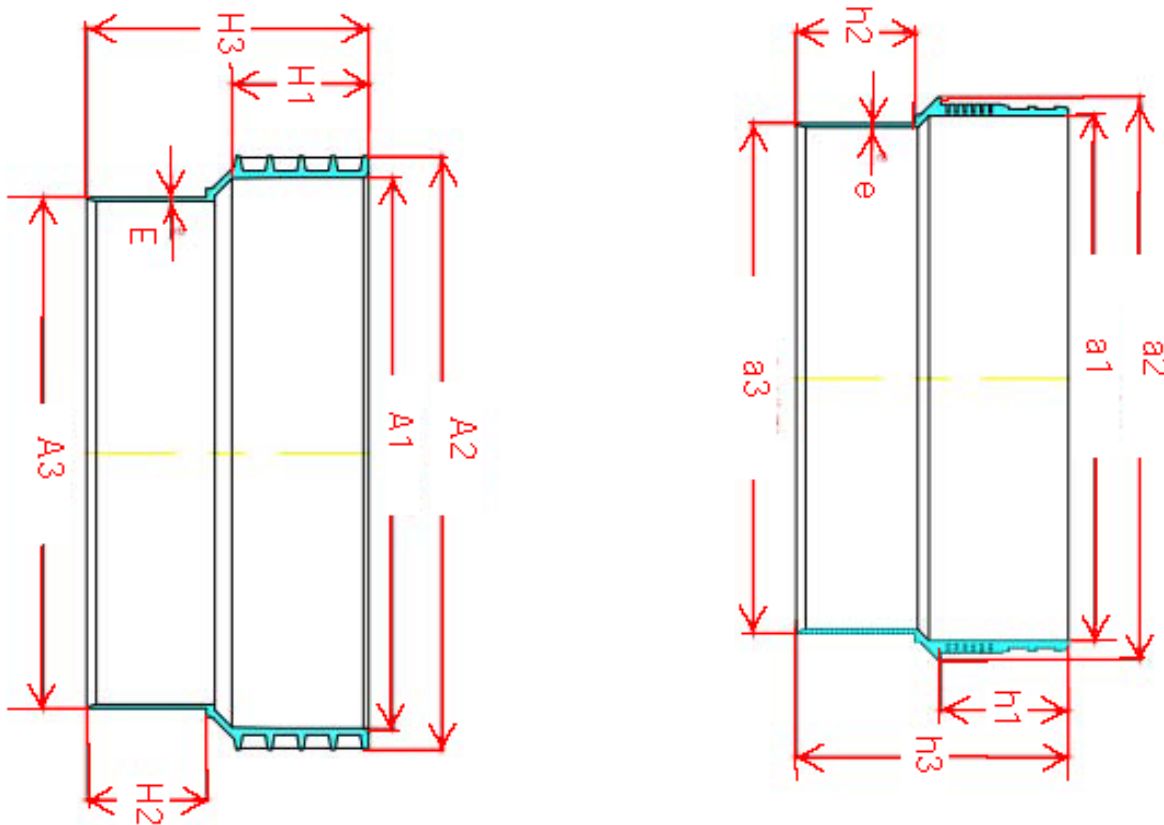

No	Coupler Size	Part	A1/a1 /mm	A2/a2 /mm	A3/a3 /mm	E/e /mm	H1/h1 /mm	H2/h2 /mm	H3/h3 /mm
1	300mm	A	337	386	294	4	160	90	300
		a	317	357	294	4	150	90	290
2	400mm	A	438	487	393	4	160	90	300
		a	418	458	393	4	150	90	290
3	500mm	A	537	591	493	4.5	160	105	315
		a	514	558.5	493	4.5	150	105	305
4	600mm	A	640	694	593	4.8	160	105	315
		a	615	659.5	593	4.8	150	105	305
5	800mm	A	845	888	793	5	160	140	315
		a	805	831	793	5	150	140	305
6	1000mm	A	1038	1081	983	5	170	165	340
		a	998	1026	983	5	150	165	330