



# Grooved Flexible Coupling

## □ Generality

Shanghai Barico Industrial Co., Ltd. was established in 2017. Since its establishment, the company has been engaged in research on flexible joints, including sleeve type, groove type, snap ring type, and connection coupling for various medium and temperature pipeline systems. It is suitable for Cast iron pipe, steel pipe and stainless steel pipe system.

Pipe connection and sealing technology is our core. The couplings we provide can solve the problems of pipe connection, installation, thermal expansion, settlement, shock absorption, etc.

## □ Executive standards

GB/T 5135.11-2006	Automatic sprinkler systems - Part 11: Grooved pipe fittings
GB/T 8260-2008	Technical specifications for grooved type flexible pipe couplings
GB/T 8259-2008	Types and dimensions of grooved type flexible pipe couplings
AWWA C606-2006	Grooved and Shouldered Joints
GB/T3098.1-2010	Mechanical properties of fasteners - Bolts, screws, and studs
GB/T3098.2-2015	Mechanical properties of fasteners - Nuts
GB/T528-2009	Vulcanized rubber or thermoplastic rubber tensile stress-strain Measurement of energy
GB/T1690-2010	Test method for liquid resistance of vulcanized or thermoplastic rubber

## □ Working principle



## □ Application occasions

- Compressed air system
- Vacuum pump system
- diesel engine
- Air dryer
- Freezer
- water pump
- Water treatment equipment
- Tap water pipeline
- drinking water
- Seawater desalination treatment
- Antifreeze chemical product pipeline
- Other process pipelines, etc.

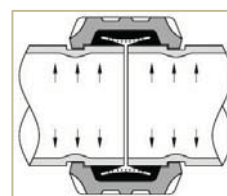

**PRESSURIZED**

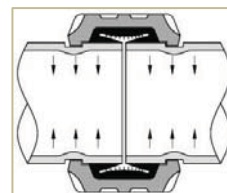

**VACUUM**

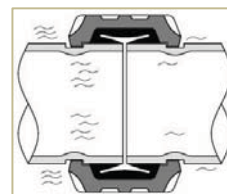

**VIBRATION  
ATTENUATION**

# Grooved Flexible Coupling

## □ Groove connection technology

Barico groove type piping system provides convenient, fast, safe, and reliable piping methods. In the continuous development process, products have gradually developed from partial specifications of joints and accessories to a complete system, and products have also gradually developed from Chinese standards to cover multiple national standards such as GB, ANSI, ISO, DIN, BS, JIS, AS, etc. The groove type coupling is the core of the groove type piping system, its structural principle and performance have been verified by customers and time.

## □ Basic Description

The groove coupling consists of four basic elements, namely the groove, coupling housing, sealing ring, and bolt/nut. Similar to groove type connection methods, there are flange type connection methods, welding ring type connection methods, etc., and the flange or welding ring, like the groove, engages with the coupling to achieve the function of pipeline connection. However, both flange type or welding ring type require welding the flange or clamp ring at the end of the pipeline. There is a certain amount of tedious work in actual commercial construction, but it will also achieve very good results in industrial or pipeline prefabrication situations.

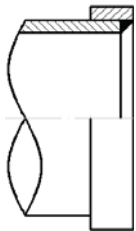

Flange type tube end



Welding ring type pipe end

The Barico groove type piping system can adopt rolling groove and cutting groove methods. Generally, the groove is directly processed at the pipe end, but in special circumstances, groove type short pipes, such as spiral steel pipes and prefabricated pipe fittings, can also be welded at the pipe end. Barico's groove standards meet relevant standards such as GB5135.11, GB/T8259, GB/T8260, AWWA C606, ISO/DIS 6182-12, etc.

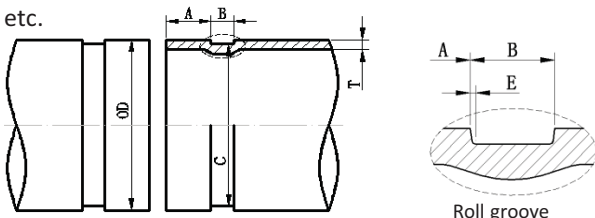

Roll groove

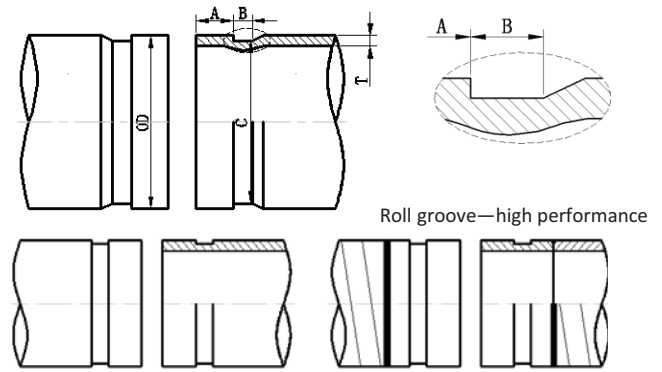

Roll groove—high performance

Note 1: For groove parameters related to rolling and cutting, please refer to relevant information from Barico.

Note 2: For detailed information on high-performance

grooves, please refer to the relevant information of Barico.

The dimensions shown in the figure have been standardized and standardized over the long term, with the dimensions of A, B, and C being extremely critical. A: Sealing surface length, B: groove width, C: groove bottom diameter.

The A dimension must be able to accommodate the sealing lip width of the sealing ring and allow for the movement of the coupling key in the B dimension. The A dimension allows the groove to have sufficient length from the pipe end to withstand sufficient load to adapt to the pipe end force caused by internal pressure in the pipeline and the longitudinal and lateral forces applied externally.

The size of B should be large enough to adapt to and adjust the key of the joint, which is the part where the coupling key meshes with the full circumference groove to prevent pipe separation caused by pipe pressure. The size of B should be larger than the width of the coupling key, so that when K750 (or K77, R77, SG7, SG7P, C3, C5) joints are used, the pipe can produce a certain axial displacement to adapt to the Thermal expansion of the pipe, which is also necessary for flexible joints to produce a certain deflection angle.

The size C is crucial and must be coaxial with the outer diameter of the pipeline, with sufficient depth to engage the coupling keys moderately to resist pipe end loads, but not too deep to prevent damage to the pipeline. Compared to the standard for threaded connections, the depth of the groove is slightly shallower.

# Grooved Flexible Coupling

## □ Sealing ring structure

The groove piping method has two important concepts. One is the concept of groove connection, and the other is the concept of C-ring reactive sealing. The shell of the coupling provides a sealed cavity for the sealing ring, while accurately positioning the sealing ring to achieve sealing effect. The key of the shell is fully engaged in the entire groove circumference of the pipeline, forming a whole and achieving a solid connection effect.



## □ Sealing technology

The section of Barico seal ring is composed of back, rib and lip. The rib serves as the support of the seal, and the lip mainly provides the main part of the sealing compression force. The three parts are organically formed according to the principle of elastic sealing and Fluid mechanics. The C-shaped structure ensures triple effective sealing of the coupling and ensures long-term use.

The installation structure characteristics of the Barico sealing ring in Barico form a triple seal when installed at the end of the pipeline. As long as the sealing ring material meets the requirements of the medium and is within the allowable working pressure and temperature range, it will achieve a long-term and leak free effect.

### First seal

The inner diameter of the sealing ring is slightly smaller than the outer diameter of the pipeline, and it is equipped with a bell shaped sealing lip. When installed on the surface of the pipeline (size A), the inner diameter of the sealing ring expands. Due to the elasticity of the rubber, the sealing ring expands to the surface of the pipeline, providing compression force to the pipeline surface through the sealing lip, thus achieving the first sealing of the C-type seal, which is the O-ring sealing principle.



C type sealing ring

E type sealing ring

### Second seal

The outer diameter of the sealing ring installed on the surface of the pipeline is slightly enlarged, and the inner diameter of the sealing chamber of the joint shell matches the outer diameter of the sealing ring. During the installation process, the sealing ring that expands on the pipeline surface is gradually compressed by tightening the bolts until the shell is installed in place. At this time, the sealing ring can also be fully compressed in place. The sealing ring reduces its height due to compression, and once again provides pressure to the pipeline surface through the sealing lip, thus achieving the second sealing of the C-type seal, which is the gasket sealing principle.

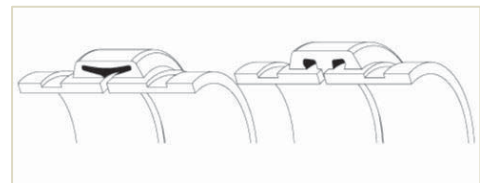

Principle of compression sealing

### Third seal

When the inside of the pipe is filled with medium and pressurized, according to the principle of Fluid mechanics, the pressure of the medium acts evenly on the inner cavity surface of the seal ring and is perpendicular to the surface. The pressure of the medium provides pressure to the surface of the pipeline again through the sealing lip, and acts on the surface of the pipeline, forming a third seal, which is the reactive sealing principle.

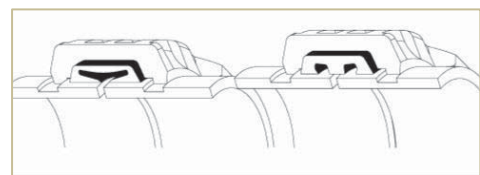

Principle of reactive sealing

## Grooved Flexible Coupling

So the application recommendations for occasions are only "general recommendations". It should be noted that in certain applications, Barico does not recommend the use of these types of sealing rings. For specific application recommendations and non recommended applications, timely reference should be made to the latest information from Barico.

The recommended recommendation table for sealing rings is only applicable to Barico's sealing rings. The suggestion for a specific purpose does not mean that the coupling, related accessories, or other components are also suitable for this application.

For easy identification, the Barico sealing ring is clearly marked with its model, specification, material, etc.

### □ Drinking water

The sealing ring made of Barico silicone rubber material is suitable for drinking water pipeline systems and has passed the Shanghai Municipal Health Approval Document, with the approval number: Hu Wei Shui Zi [2007] S0004; And is in the process of passing the type inspection of the Chinese Center for Disease Control and Prevention Environmental and Health Related Product Safety Institute.

Note: According to customer needs, sealing rings made of EPDM material can also be applied to drinking water pipeline systems.

### □ Selection of sealing ring



warn

To ensure that the sealing ring is suitable for different working conditions and achieve the longest ideal life, it is necessary to choose the correct type and material of the sealing ring when ordering. For specific chemical media and temperature applications, please refer to Seal Ring Selection and Chemical Applications.

**Incorrect selection of sealing rings may lead to personal injury, property damage, installation errors, joint leakage, and connection failure.**

Grade	Material	component	Colour	Temperature Range°C		Application Occasions
F1	Viton	FKM	Brown	-20	160	Oil, oily air
F	Viton	FKM	Black + white line	-30	200	Oil, oily air
Q1	Silicon rubber	Q	Tender green	-70	235	Oil free air
Q2	Silicon rubber	Q	Purplish red	-70	177	Cold and hot water, oil-free air
Q3	Silicon rubber	Q	Milky white	-70	135	Drinking water and food industry
Q4	Silicon rubber	Q	Grey	-70	280	Oil free air
E	EPDM	EPDM	Black	-35	110	Water pipe
E1	EPDM	EPDM	Black + Purple Line	-45	110	Antifreeze chemicals and dilute acids
C	Neoprene	CR	Black + red line	-35	120	Seawater, pH



# Grooved Flexible Coupling

## □ C6 Lightweight stainless steel coupling (appearance patent)

**Describe:**

Size: 1"-12" (DN25-300)

Maximum work pressure: 2.5Mpa (365psi)

Material: Standard configuration 304, optional 316 and 316L etc.

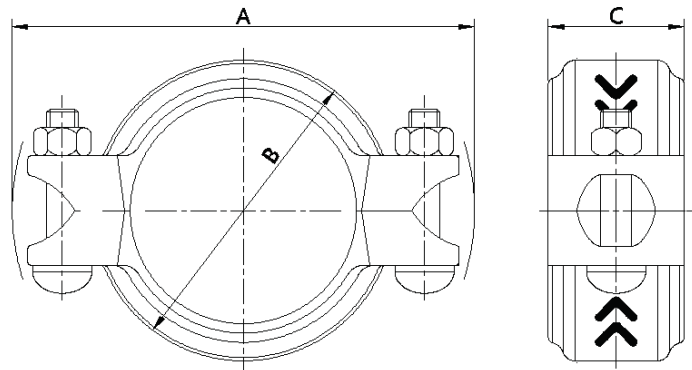

**Parameter table:**

Size		Max. Work Pressure		End Load	Pipe End Separation	Angular	A	B	C	Bolt Size	Install Torque
in	mm	Mpa	Psi	N	mm	Degree	mm	mm	mm	mm	N.m
1¼	42.4	2.5	350	3530	0-2.2	2.15	112	65	42	M10x45	30-40
1½	48.3	2.5	350	4581	0-2.2	1.80	115	65	42	M10x45	30-40
2	60.3	2.5	350	7139	0-2.2	1.72	128	80	42	M10x45	30-40
2½	73.0	2.5	350	10463	0-2.2	1.41	145	93	43	M10x45	30-40
3OD	76.1	2.5	350	11371	0-2.2	1.41	148	97	43	M10x45	30-40
3	88.9	2.5	350	15518	0-2.2	1.36	157	110	44	M10x50	30-40
4¼OD	108.0	2.5	350	22902	0-3.6	—	176	130	45	M10x55	30-40
4	114.3	2.5	350	25652	0-3.6	—	183	137	45	M10x55	30-40
5¼OD	133.0	2.5	350	34732	0-3.6	—	216	157	47	M12x70	60-80
5½OD	139.7	2.5	350	38320	0-3.6	—	223	163	47	M12x70	60-80
6¼OD	159.0	2.5	350	49639	0-4.6	—	245	183	48	M12x70	60-80
6½OD	165.1	2.5	350	53521	0-4.6	—	252	190	48	M12x70	60-80
8	219.1	2.1	300	79176	0-6.0	—	310	248	59	M16x90	120-140
10	273.0	2.1	300	122923	0-6.0	—	385	310	60	M22x130	240-280
12	323.9	2.1	300	173033	0-6.0	—	436	362	61	M22x130	240-280

- The dimensions of this structure refer to the dimensions after installation. Specifications below DN100 are flat mouth structures, while specifications above DN100 are male and female mouth structures.
- The table indicates the installation torque for each specification of coupling, which ensures that the coupling is installed in place and achieves effective sealing. If the installation torque does not meet the requirements, it will result in unsuccessful coupling installation. Attention: Do not exceed the specified maximum torque value during installation, otherwise it may cause bolt fracture and ultimately affect the service life of the coupling. When tightening stainless steel nuts, please be sure to apply lubricant to prevent locking!



# Grooved Flexible Coupling

## □ C5 Standard stainless steel flexible coupling (utility model patent)

**Describe:**

Size:1"-12"(DN25-300)

Maximum work pressure:6.9Mpa(1000psi)

Certification pressure:2.5Mpa(365psi)

Material: Standard configuration 304, optional 316316L and duplex stainless steel, etc.

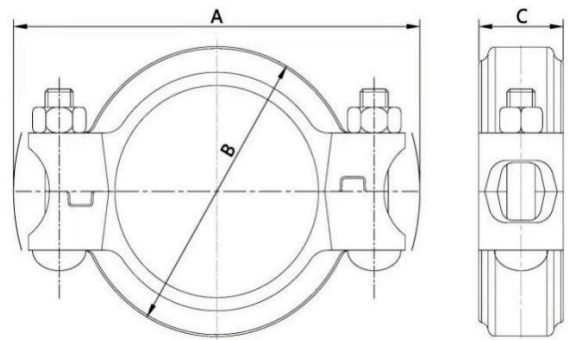

**Parameter table:**

Size		Certification pressure	Max. Work Pressure	End Load	Pipe End Separation	Angular	A	B	C	Bolt Size	Install Torque
in	mm	Mpa	Mpa	N	mm	Degree	mm	mm	mm	mm	N.m
1	33.7	—	6.9	6154	0-3.2	3.22	100	58	43	M10x50	40-60
1¼	42.4	—	6.9	7942	0-3.2	3.15	112	65	43	M10x50	40-60
1½	48.3	—	6.9	12642	0-3.2	2.80	118	71	43	M10x50	40-60
2½OD	57.0	—	4.0	10207	0-3.2	2.42	129	85	43	M10x50	40-60
2	60.3	2.5	4.0	11423	0-3.2	2.22	132	88	43	M10x50	40-60
2½	73.0	2.5	4.0	16742	0-3.2	2.11	150	101	43.5	M10x50	40-60
3OD	76.1	2.5	4.0	18194	0-3.2	2.05	155	106	43.5	M10x50	40-60
3	88.9	2.5	4.0	24829	0-3.2	1.86	167	120	43.5	M10x50	40-60
3½	101.6	2.5	4.0	32429	0-6.4	1.75	192	136	46.5	M12x70	60-80
4¼OD	108.0	2.5	4.0	36644	0-6.4	1.72	199	144	46.5	M12x75	60-80
4	114.3	2.5	4.0	41043	0-6.4	1.66	203	149	46.5	M12x75	60-80
5¼OD	133.0	2.5	4.0	55572	0-6.4	1.56	238	170	48	M16x90	80-120
5½OD	139.7	2.5	4.0	61312	0-6.4	1.33	243	176	48	M16x90	80-120
6¼OD	159.0	2.5	4.0	79423	0-6.4	1.25	269	203	50	M16x90	80-120
8	219.1	2.5	4.0	150812	0-6.4	1.12	343	265	60	M20x100	180-220
10	273.0	2.5	3.45	201946	0-6.4	1.04	402	319	61	M22x130	240-280
12	323.9	2.5	3.45	284270	0-6.4	0.95	455	370	62	M22x130	240-280

- For more detailed specifications, please consult Barico.
- The dimensions of this structure refer to the dimensions after installation.
- The table indicates the installation torque for each specification of coupling, which ensures that the coupling is installed in place and achieves effective sealing. If the installation torque does not meet the requirements, it will result in unsuccessful coupling installation. Attention: Do not exceed the specified maximum torque value during installation, otherwise it may cause bolt fracture and ultimately affect the service life of the coupling.



# Grooved Rigid Coupling

## □ C4 Standard stainless steel rigid coupling (appearance patent)

**Describe:**

Size:1"-12"(DN25-300)

Maximum work pressure:4.0Mpa(600psi)

Certification pressure:2.5Mpa(365psi)

Material: Standard configuration 304, optional 316316L and duplex stainless steel, etc.

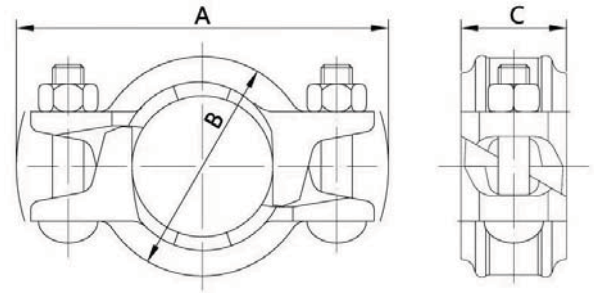

**Parameter table:**

Size		Certification pressure	Max. Work Pressure	End Load	Pipe End Separation	A	B	C	Bolt Size	Install Torque
in	mm	Mpa	Mpa	N	mm	mm	mm	mm	mm	N.m
1	33.7	—	4.0	3568	0-3.2	100	58	45	M10x50	25-35
1¼	42.4	—	4.0	5648	0-3.2	112	65	45	M10x50	25-35
1½	48.3	—	4.0	7329	0-3.2	118	71	45	M10x50	25-35
2½OD	57.0	—	4.0	10207	0-3.2	129	85	45	M10x50	25-35
2	60.3	2.5	4.0	11423	0-3.2	132	88	46	M10x50	25-35
2½	73.0	2.5	4.0	16742	0-3.2	150	101	46	M10x60	25-35
3OD	76.1	2.5	4.0	18194	0-3.2	155	106	46	M10x60	25-35
3	88.9	2.5	4.0	24829	0-3.2	167	120	48	M10x60	25-35
4¼OD	108.0	2.5	4.0	36644	0-6.4	199	144	51	M10x60	25-35
4	114.3	2.5	4.0	41043	0-6.4	203	149	51	M10x60	25-35
5¼OD	133.0	2.5	4.0	55572	0-6.4	238	170	51	M12x70	60-70
5½OD	139.7	2.5	4.0	61312	0-6.4	243	176	51	M12x70	60-70
6¼OD	159.0	2.5	4.0	79423	0-6.4	269	203	52	M12x70	60-70
8	219.1	2.5	4.0	150812	0-6.4	343	265	61	M16x95	80-120
10	273.0	2.5	2.75	160971	0-6.4	402	319	63	M22x130	240-280
12	323.9	2.5	2.75	226592	0-6.4	455	370	64	M22x130	240-280

- For more detailed specifications, please consult Barico
- The dimensions of this structure refer to the dimensions after installation.
- The table indicates the installation torque for each specification of coupling, which ensures that the coupling is installed in place and achieves effective sealing. If the installation torque does not meet the requirements, it will result in unsuccessful coupling installation. Attention: Do not exceed the specified maximum torque value during installation, otherwise it may cause bolt fracture and ultimately affect the service life of the coupling.



# Grooved Flexible Coupling

## □ C3 Heavy duty stainless steel flexible coupling

**Describe:**

Size:1"-12"(DN25-300)

Maximum work pressure:16.0Mpa(2350psi)

Material: Standard configuration 316, optional 316L, duplex stainless steel, etc.

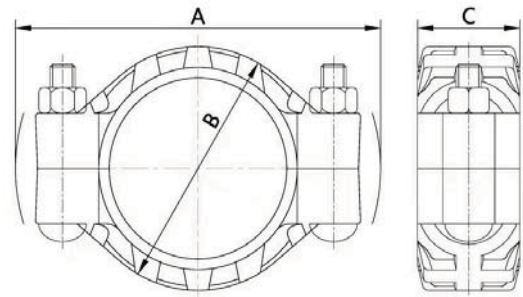

**Parameter table:**

Size		Max. Work Pressure	End Load	Pipe End Separation	Angular	A	B	C	Bolt Size	Install Torque
in	mm	Mpa	N	mm	Degree	mm	mm	mm	mm	N.m
3/4	26.9	16.0	9093	0-3.2	3.35	92	51	44	M10x40	40-60
1	33.7	16.0	14272	0-3.2	3.22	100	58	45	M10x40	40-60
1 1/4	42.4	16.0	22591	0-3.2	3.15	112	65	45	M10x50	40-60
1 1/2	48.3	16.0	29316	0-3.2	2.80	118	71	45	M10x50	40-60
2	60.3	10.0	28558	0-3.2	2.52	132	88	47	M12x70	80-90
2 1/2	73.0	10.0	41854	0-3.2	2.41	150	101	48	M12x70	80-90
3OD	76.1	10.0	45484	0-3.2	2.41	155	106	48	M12x70	80-90
3	88.9	10.0	62072	0-3.2	2.06	167	120	48	M12x70	80-90
4 1/4OD	108.0	10.0	91609	0-6.4	2.42	199	144	49	M16x90	100-120
4	114.3	10.0	102608	0-6.4	2.21	203	149	49	M16x90	100-120
5 1/4OD	133.0	8.6	119479	0-6.4	2.16	238	170	50	M20x100	180-220
5 1/2OD	139.7	8.6	131820	0-6.4	2.03	243	176	50	M20x100	180-220
6	168.3	8.6	191318	0-6.4	1.85	280	213	51	M22x120	240-280
8	219.1	8.6	324245	0-6.4	1.72	343	265	63	M22x120	240-280
10	273.0	6.9	403891	0-6.4	1.54	402	319	63	M24x150	320-360
12	323.9	5.5	453183	0-6.4	1.22	455	370	64	M24x150	320-360
14	355.6	4.0	397258	0-6.4	1.02	489	403	74	M24x150	320-360
16	406.4	3.45	447524	0-6.4	0.88	542	458	74	M24x150	320-360
18	457.2	2.75	451476	0-6.4	0.75	595	512	74	M24x150	320-360

- For more detailed specifications, please consult Barico.
- The dimensions of this structure refer to the dimensions after installation.
- The table indicates the installation torque for each specification of coupling, which ensures that the coupling is installed in place and achieves effective sealing. If the installation torque does not meet the requirements, it will result in unsuccessful coupling installation. Attention: Do not exceed the specified maximum torque value during installation, otherwise it may cause bolt fracture and ultimately affect the service life of the coupling.



## Grooved Flexible Coupling

### □ K70 Positioning type flexible coupling

Describe:

Size:1"-4"(DN25-100)

Maximum work pressure:6.9Mpa(1000psi)

Material: Standard configuration QT450-12 Ductile Iron

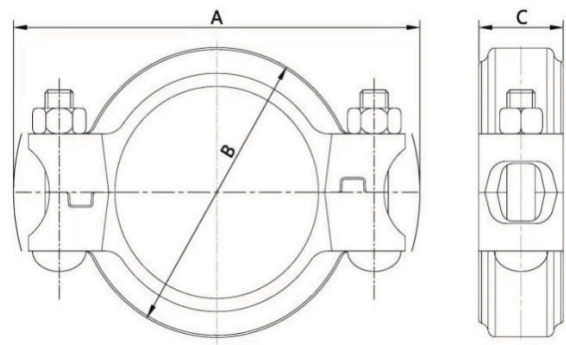

#### Parameter Table:

Size		Max. Work Pressure	End Load	Pipe End Separation	Angular	A	B	C	Bolt Size	Install Torque
in	mm	Mpa	N	mm	度	mm	mm	mm	mm	N.m
1	33.7	6.9	892	0-3.2	5.45	56	98	43	M10x50	40-60
1¼	42.4	6.9	1412	0-3.2	4.33	65	112	43	M10x50	40-60
1½	48.3	6.9	1832	0-3.2	3.8	71	118	43	M10x55	40-60
2¼OD	54.0	6.9	2290	0-3.2	3.4	82	126	45	M10x55	40-60
2½OD	57.0	6.9	2552	0-3.2	3.4	85	129	45	M10x55	40-60
2	60.3	6.9	2856	0-3.2	3.22	88	132	45	M10x55	40-60
2½	73.0	4.0	4185	0-3.2	2.41	101	150	45	M10x55	40-60
3OD	76.1	4.0	4548	0-3.2	2.41	106	155	45	M10x60	40-60
3	88.9	4.0	6207	0-3.2	2.06	120	167	46	M10x60	40-60
3½	101.6	4.0	8107	0-6.4	1.8	135	182	52	M12x75	80-120
4¼OD	108.0	4.0	9161	0-6.4	3.4	144	199	52	M12x75	80-120
4	114.3	4.0	10261	0-6.4	3.4	149	203	52	M12x75	80-120

- For larger specifications, please refer to K750 type coupling.
- The dimensions of this structure refer to the dimensions after installation.
- The ΔL size facilitates the selection of wrench socket depth.
- The table indicates the installation torque for each specification of coupling, which ensures that the coupling is installed in place and achieves effective sealing. If the installation torque does not meet the requirements, it will result in unsuccessful coupling installation. Attention: Do not exceed the specified maximum torque value during installation, otherwise it may cause bolt fracture and ultimately affect the service life of the coupling.

# Grooved Flexible Coupling

## □ K750 Standard flexible coupling

Describe:

Size:1''-12''(DN25-300)

Maximum work pressure:5.2Mpa(750psi)

Material: Standard configuration QT450-12 Ductile Iron

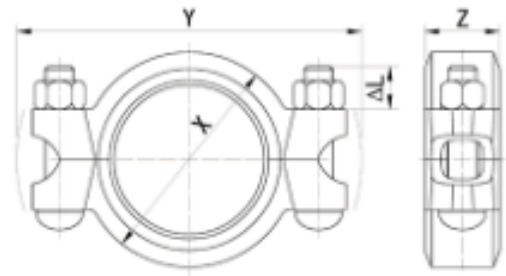

Parameter Table:

Size		Max.Work Pressure	End Load	Pipe End Separation	Angular	X	Y	Z	AL	Bolt Size	Install Torque
in	mm	Mpa	N	mm	Degree	mm	mm	mm	mm	mm	N.m
1	33.7	5.2	4638	0-3.2	5.45	58	100	45	15	M10x50	40-60
1¼	42.4	5.2	7342	0-3.2	4.33	65	112	45	15	M10x50	40-60
1½	48.3	5.2	9528	0-3.2	3.8	71	118	45	15	M10x55	40-60
2¼OD	54.0	5.2	11909	0-3.2	3.4	82	126	48	15	M10x55	40-60
2½OD	57.0	5.2	13269	0-3.2	3.4	85	129	48	15	M10x55	40-60
2	60.3	5.2	14850	0-3.2	3.22	88	132	48	15	M10x55	40-60
2½	73.0	5.2	21669	0-3.2	2.41	101	150	48	15	M10x55	40-60
3OD	76.1	5.2	23652	0-3.2	2.41	106	155	48	15	M10x60	40-60
3	88.9	5.2	32277	0-3.2	2.06	120	167	48	15	M10x60	40-60
3½	101.6	5.2	42158	0-6.4	1.8	135	182	54	23	M12x75	80-120
4¼OD	108.0	5.2	47637	0-6.4	3.4	144	199	54	23	M12x75	80-120
4	114.3	5.2	53356	0-6.4	3.4	149	203	54	23	M12x75	80-120
5¼OD	133.0	5.2	72243	0-6.4	2.76	170	238	54	32	M16x90	180-230
5½OD	139.7	5.2	79705	0-6.4	2.63	176	243	54	32	M16x90	180-230
6¼OD	159.0	5.2	103249	0-6.4	2.41	203	269	54	32	M16x90	180-230
6	168.3	5.2	115681	0-6.4	2.2	207	278	54	32	M16x90	180-230
8	219.1	5.2	154582	0-6.4	1.7	265	343	63	36	M20x100	280-350
10	273.0	5.2	242212	0-6.4	1.5	319	402	63	36	M20x120	280-350
12	323.9	5.2	340951	0-6.4	1.2	370	455	64	36	M20x120	280-350

- For larger specifications, please refer to K77 type coupling.
- The dimensions of this structure refer to the dimensions after installation.
- The ΔL size facilitates the selection of wrench socket depth.
- The table indicates the installation torque for each specification of coupling, which ensures that the coupling is installed in place and achieves effective sealing. If the installation torque does not meet the requirements, it will result in unsuccessful coupling installation. Attention: Do not exceed the specified maximum torque value during installation, otherwise it may cause bolt fracture and ultimately affect the service life of the coupling.



# Grooved Flexible Coupling

## □ K79 High pressure flexible coupling

Describe:

Size:11"-12"(DN25-300)

Maximum work pressure:16Mpa(2350psi)

Material: Standard configuration QT450-12 Ductile Iron

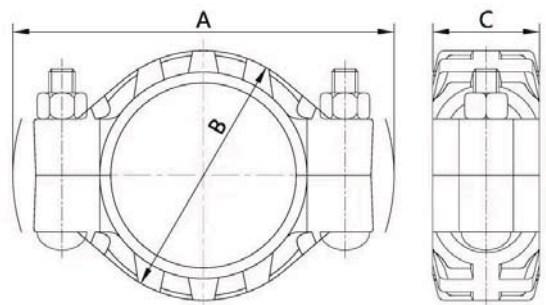

### Parameter Table:

Size		Max.Work Pressure	End Load	Pipe End Separation	Angular	A	B	C	Bolt Size	Install Torque
in	mm	Mpa	N	mm	度	mm	mm	mm	mm	N.m
1	33.7	16.0	14272	0-3.2	3.22	120	60	47	M12x50	40-60
1¼	42.4	16.0	22591	0-3.2	3.15	114	67	47	M12x60	40-60
1½	48.3	16.0	29316	0-3.2	2.80	120	73	47	M12x60	40-60
2	60.3	10.0	28558	0-3.2	2.52	134	90	48	M12x70	80-90
2½	73.0	10.0	41854	0-3.2	2.41	152	103	48	M12x70	80-90
3OD	76.1	10.0	45484	0-3.2	2.41	155	106	48	M12x70	80-90
3	88.9	10.0	62072	0-3.2	2.06	167	120	50	M12x70	80-90
4¼OD	108.0	10.0	91609	0-6.4	2.42	201	146	51	M16x90	100-120
4	114.3	10.0	102608	0-6.4	2.21	205	151	51	M16x90	100-120
5¼OD	133.0	8.6	119479	0-6.4	2.16	242	175	52	M20x100	180-220
5½OD	139.7	8.6	131820	0-6.4	2.03	245	179	52	M20x100	180-220
6	168.3	8.6	191318	0-6.4	1.85	282	215	53	M20x100	240-280
8	219.1	8.6	324245	0-6.4	1.72	345	268	65	M22x120	240-280
10	273.0	6.9	403891	0-6.4	1.54	405	321	65	M24x150	320-360
12	323.9	5.5	453183	0-6.4	1.22	458	373	66	M24x150	320-360

- For larger specifications, please consult with Barico.
- The dimensions of this structure refer to the dimensions after installation.
- The table indicates the installation torque for each specification of coupling, which ensures that the coupling is installed in place and achieves effective sealing. If the installation torque does not meet the requirements, it will result in unsuccessful joint installation. Attention: Do not exceed the specified maximum torque value during installation, otherwise it may cause bolt fracture and ultimately affect the service life of the coupling.

# Grooved Flexible Coupling

## □ K77 Large diameter flexible coupling

Describe:

Size:14''-40''(DN350-1000)

Maximum work pressure:2.5Mpa(365psi)

Material: Standard configuration QT450-12 Ductile Iron

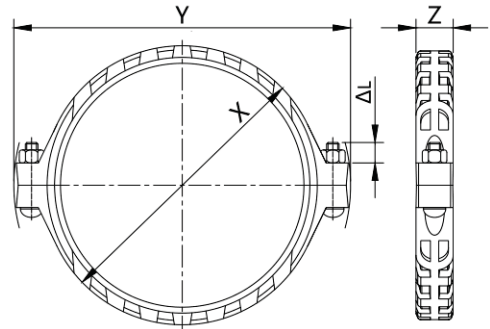

### Parameter Table:

Size		Max.Work Pressure	End Load	Pipe End Separation	Angular	X	Y	Z	AL	Bolt Size	Install Torque
in	mm	Mpa	N	mm	Degree	mm	mm	mm	mm	mm	N.m
14	355.6	2.5	248287	0-6.0	0.60	420	510	74	40	2xM24x150	520-600
350	377.0	2.5	279070	0-6.0	0.60	441	531	74	40	2xM24x150	520-600
16	406.4	2.5	324293	0-6.0	0.45	470	570	74	40	2xM24x150	520-600
400	426.0	2.5	356327	0-6.0	0.45	490	590	74	40	2xM24x150	520-600
18	457.2	2.5	410433	0-6.0	0.40	544	630	76	40	2xM24x150	520-600
450	480.0	2.5	452389	0-6.0	0.40	567	653	76	40	2xM24x150	520-600
20	508.0	2.5	506707	0-6.0	0.37	595	680	77	44	2xM27x140	640-720
500	530.0	2.5	551546	0-6.0	0.37	617	702	77	44	2xM27x140	640-720
22	558.8	2.5	613116	0-6.0	0.34	646	735	77	44	2xM27x140	640-720
24	609.6	2.5	729659	0-8.0	0.30	700	780	80	44	2xM27x140	640-720
600	630.0	2.5	779311	0-8.0	0.30	720	800	80	44	2xM27x140	640-720
26	660.4	1.6	548055	0-12.1	0.30	751	832	120	50	2xM27x150	640-720
28	711.2	1.6	635614	0-12.1	0.24	820	895	120	50	2xM27x150	640-720
700	720.0	1.6	651441	0-12.1	0.24	830	905	120	50	2xM27x150	640-720
30	762.0	1.6	729659	0-12.1	0.22	883	960	125	40	2xM27x150	640-720
32	812.8	1.6	830190	0-12.1	0.20	942	1022	125	50	2xM30x180	760-880
800	820.0	1.6	865697	0-12.1	0.20	952	1035	125	50	2xM30x180	780-880
36	914.4	1.6	1050709	0-12.1	0.18	1055	1138	130	40	2xM33x180	920-1060
40	1016.0	1.6	1297171	0-12.1	0.15	1168	1245	138	40	2xM33x180	920-1060

- For larger specifications, please consult with Barico.
- The dimensions of this structure refer to the dimensions after installation.
- The ΔL size facilitates the selection of wrench socket depth.
- The table indicates the installation torque for each specification of coupling, which ensures that the coupling is installed in place and achieves effective sealing. If the installation torque does not meet the requirements, it will result in unsuccessful joint installation. Attention: Do not exceed the specified maximum torque value during installation, otherwise it may cause bolt fracture and ultimately affect the service life of the coupling.



# Grooved Flexible Coupling

## □ R77 High performance groove coupling

Describe:

Size:14"-48"(DN350-1200)

Maximum work pressure:2.5Mpa(365psi)

Material: Standard configuration

QT450-12 Ductile Iron

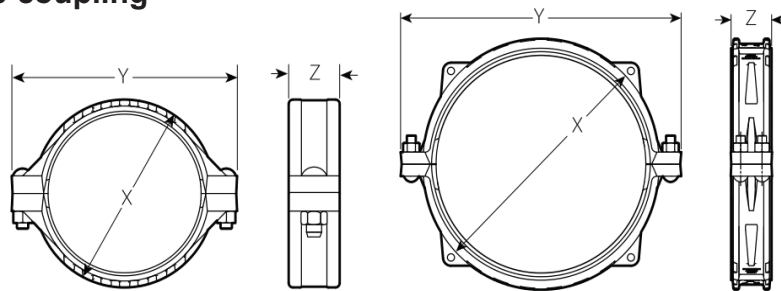

Parameter Table:

Size		Max. Work Pressure	End Load	Pipe End Separation	Angular	X	Y	Z	Bolt Size	Install Torque
in	mm	Mpa	N	mm	Degree	mm	mm	mm	mm	N.m
14	355.6	2.5	248287	3.3-7.9	0.73	407	520	120	2xM24x140	520-600
350	377.0	2.5	279070	3.3-7.9	0.69	428	542	120	2xM24x140	520-600
16	406.4	2.5	324293	3.3-7.9	0.64	465	572	120	2xM24x140	520-600
400	426.0	2.5	356327	3.3-7.9	0.61	485	592	120	2xM24x140	520-600
18	457.2	2.5	410433	3.3-7.9	0.57	519	622	120	2xM24x140	520-600
450	480.0	2.5	452389	3.3-7.9	0.54	442	645	120	2xM24x140	520-600
20	508.0	2.5	506707	3.3-7.9	0.51	575	705	120	2xM27x140	640-720
500	530.0	2.5	551546	3.3-7.9	0.49	600	730	120	2xM27x140	640-720
22	558.8	2.5	613116	3.3-7.9	0.46	630	760	120	2xM27x150	640-720
24	609.6	2.5	729659	3.3-7.9	0.42	690	810	120	2xM27x150	640-720
600	630.0	2.5	779311	3.3-7.9	0.41	710	830	120	2xM27x150	640-720
26	660.4	2.5	779311	3.8-13.5	0.83	755	895	150	4xM27x150	640-720
28	711.2	2.5	856336	3.8-13.5	0.77	820	942	150	4xM27x150	640-720
700	720.0	2.5	1017876	3.8-13.5	0.75	830	950	150	4xM27x150	640-720
30	762.0	2.5	1140092	3.8-13.5	0.72	872	1010	150	4xM30x180	640-720
32	812.8	2.5	1297171	3.8-13.5	0.68	925	1060	150	4xM30x180	760-880
800	820.0	2.5	1320254	3.8-13.5	0.66	933	1068	150	4xM30x180	760-880
36	914.4	2.5	1641732	5.3-15.0	0.60	1030	1160	150	4xM30x180	760-880
40	1016.0	1.6	1297171	5.3-15.0	0.54	1125	1285	170	4xM36x200	1180-1350
44	1117.6	1.6	1569577	5.3-15.0	0.50	1240	1390	170	4xM36x200	1180-1350
48	1219.2	1.6	1867926	5.3-15.0	0.45	1342	1493	170	4xM36x200	1180-1350

- The dimensions of this structure refer to the dimensions after installation.
- The ΔL size facilitates the selection of wrench socket depth.
- The table indicates the installation torque for each specification of coupling, which ensures that the coupling is installed in place and achieves effective sealing. If the installation torque does not meet the requirements, it will result in unsuccessful coupling installation. Attention: Do not exceed the specified maximum torque value during installation, otherwise it may cause bolt fracture and ultimately affect the service life of the coupling.



# Grooved Flexible Coupling

## □ SG7 Forged steel groove coupling—10Mpa

Describe:

Size:1"-20"(DN25-500)

Maximum work pressure:10Mpa(1500psi)

Material: Standard configuration 45# carbon steel

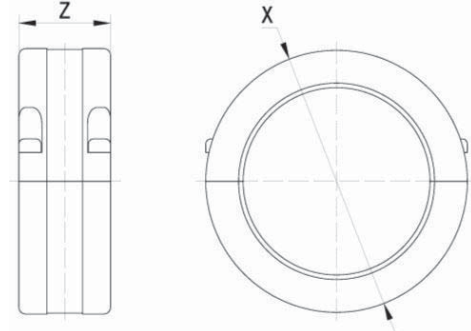

Parameter Table:

Size		Max. Work Pressure	End Load	Pipe End Separation	Angular	X	Z	Bolt Size	Install Torque
in	mm	Mpa	N	mm	Degree	mm	mm	mm	N.m
1	33.7	10.0	8920	0-3.2	2.61	73	45	4-M6x15	15-25
1¼	42.4	10.0	14120	0-3.2	2.17	81	45	4-M6x20	15-25
1½	48.3	10.0	18322	0-3.2	1.95	87	45	4-M6x20	15-25
2	60.3	10.0	28558	0-3.2	1.52	104	48	4-M8x25	40-50
2½	73.0	10.0	41854	0-3.2	1.25	115	49	4-M8x30	40-50
3OD	76.1	10.0	45484	0-3.2	1.25	118	49	4-M8x30	40-50
3	88.9	10.0	62072	0-3.2	1.10	129	50.5	4-M8x35	40-50
3½	101.6	10.0	81073	0-6.4	1.00	135	51	4-M8x40	40-50
4¼OD	108.0	10.0	91609	0-6.4	1.62	144	51.5	4-M8x40	40-50
4	114.3	10.0	102608	0-6.4	1.62	150	51.5	4-M8x40	40-50
5¼OD	133.0	10.0	138929	0-6.4	1.38	176	54	4-M10x50	70-90
5½OD	139.7	10.0	153279	0-6.4	1.38	183	54	4-M10x50	70-90
6¼OD	159.0	10.0	198557	0-6.4	1.15	214	54	4-M12x65	110-130
6	168.3	10.0	222463	0-6.4	1.09	220	54	4-M12x65	110-130
7	193.7	10.0	294679	0-6.4	0.95	254	65	4-M16x70	240-290
8	219.1	10.0	377029	0-6.4	0.85	280	65	4-M16x70	240-290
10	273.0	10.0	585349	0-6.4	0.80	336	67	4-M16x80	240-290
12	323.9	10.0	823971	0-6.4	0.75	400	68.5	4-M16x90	240-290
14	355.6	10.0	993147	0-6.4	0.62	435	75	4-M20x90	560-600
16	406.4	10.0	1297171	0-6.4	0.51	488	75	4-M20x90	560-600
18	457.2	10.0	1641732	0-6.4	0.45	538	76	4-M20x100	560-600
20	508.0	10.0	2026830	0-6.4	0.42	590	76	4-M20x100	560-600

- This product is a forged steel coupling, and the pressure level can be customized according to the actual requirements of the customer.
- The dimensions of this structure refer to the dimensions after installation.
- The table indicates the installation torque for each specification of coupling, which ensures that the coupling is installed in place and achieves effective sealing. If the installation torque does not meet the requirements, it will result in unsuccessful coupling installation. Attention: Do not exceed the specified maximum torque value during installation, otherwise it may cause bolt fracture and ultimately affect the service life of the coupling.



## Grooved Flexible Coupling

### □ SG7 Forged steel groove coupling—16Mpa

Describe:

Size:2"-12"(DN50-300)

Maximum work pressure:16Mpa(2350psi)

Material: Standard configuration 42CrMo alloy steel

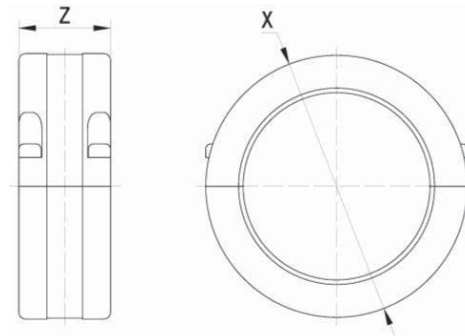

Parameter Table:

Size		Max. Work Pressure	End Load	Pipe End Separation	Angular	X	Z	Bolt Size	Install Torque
in	mm	Mpa	N	mm	Degree	mm	mm	mm	N.m
2	60.3	16.0	45692	0-3.2	1.52	110	50	4-M10x50	70-90
2½	73.0	16.0	66966	0-3.2	1.25	123	50	4-M10x50	70-90
3OD	76.1	16.0	72774	0-3.2	1.25	126	50	4-M10x50	70-90
3	88.9	16.0	99315	0-3.2	1.10	138	50	4-M10x50	70-90
3½	101.6	16.0	129717	0-6.4	1.00	140	56	4-M10x50	70-90
4¼OD	108.0	16.0	146574	0-6.4	1.62	150	56	4-M10x50	70-90
4	114.3	16.0	164173	0-6.4	1.62	158	56	4-M10x50	70-90
5¼OD	133.0	16.0	222287	0-6.4	1.38	180	58	4-M12x65	110-130
5½OD	139.7	16.0	245246	0-6.4	1.38	188	58	4-M12x65	110-130
6¼OD	159.0	16.0	317690	0-6.4	1.15	220	60	4-M16x70	240-290
6	168.3	16.0	355941	0-6.4	1.09	230	60	4-M16x70	240-290
7	193.7	16.0	471486	0-6.4	0.95	260	65	4-M16x70	240-290
8	219.1	16.0	603246	0-6.4	0.85	290	68	4-M16x80	240-290
10	273.0	16.0	936559	0-6.4	0.80	346	70	4-M20x90	560-600
12	323.9	16.0	1318353	0-6.4	0.75	410	72	4-M20x100	560-600

- This product is a forged steel coupling, and the pressure level can be customized according to the actual requirements of the customer.
- The dimensions of this structure refer to the dimensions after installation.
- The table indicates the installation torque for each specification of coupling, which ensures that the coupling is installed in place and achieves effective sealing. If the installation torque does not meet the requirements, it will result in unsuccessful coupling installation. Attention: Do not exceed the specified maximum torque value during installation, otherwise it may cause bolt fracture and ultimately affect the service life of the coupling.



# Grooved Flexible Coupling

## □ SG7 Forged steel groove coupling—25Mpa

Describe:

Size:2"-12"(DN50-300)

Maximum work pressure:25Mpa(3650psi)

Material: Standard configuration 42CrMo alloy steel, other high-performance alloy steels

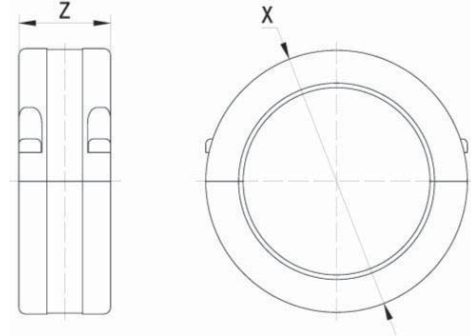

Parameter Table:

Size		Max. Work Pressure	End Load	Pipe End Separation	Angular	X	Z	Bolt Size	Install Torque
in	mm	Mpa	N	mm	Degree	mm	mm	mm	N.m
2	60.3	25.0	71394	0-3.2	2.25	120	52	4-M12x65	110-130
2½	73.0	25.0	104635	0-3.2	2.05	133	52	4-M12x65	110-130
3	88.9	25.0	155179	0-3.2	1.85	140	52	4-M12x65	110-130
3½	101.6	25.0	202683	0-6.4	1.45	150	58	4-M12x65	110-130
4	114.3	25.0	256521	0-6.4	1.25	160	58	4-M12x70	80-120
5	139.7	25.0	383198	0-6.4	1.15	198	60	4-M16x70	240-290
6	168.3	25.0	556158	0-6.4	1.05	240	62	4-M16x80	240-290
7	193.7	25.0	736698	0-6.4	0.95	270	67	4-M16x80	240-290
8	219.1	25.0	942572	0-6.4	0.90	300	70	4-M20x90	560-600
10	273.0	25.0	1463373	0-6.4	0.80	356	72	M20x100	560-600
12	323.9	25.0	2059927	0-6.4	0.75	420	74	M20x110	560-600

- This product is a forged steel coupling, and the pressure level can be customized according to the actual requirements of the customer.
- The dimensions of this structure refer to the dimensions after installation.
- The table indicates the installation torque for each specification of coupling, which ensures that the coupling is installed in place and achieves effective sealing. If the installation torque does not meet the requirements, it will result in unsuccessful coupling installation. Attention: Do not exceed the specified maximum torque value during installation, otherwise it may cause bolt fracture and ultimately affect the service life of the coupling.



## Grooved Flexible Coupling

### □ SG7P High performance forged steel groove coupling

Describe:

Size:14"-48"(DN350-1200)

Maximum work pressure:6.4Mpa(950psi)

Material: Standard configuration 42CrMo alloy steel, other high-performance alloy steels

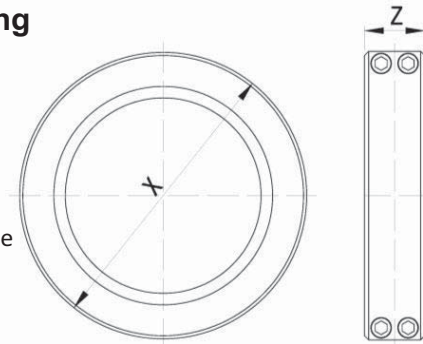

#### Parameter Table:

Size		Max. Work Pressure	End Load	Pipe End Separation	Angular	X	Z	Bolt Size	Install Torque
in	mm	Mpa	N	mm	Degree	mm	mm	mm	N.m
350	355.6	6.4	635614	20	0.73	465	116	4-M20x110	560-600
350	377.0	6.4	714418	20	0.69	488	116	4-M20x110	560-600
400	406.4	6.4	830190	20	0.64	518	118	4-M20x110	560-600
400	426.0	6.4	912198	20	0.61	538	118	4-M20x110	560-600
450	457.2	4.0	656693	20	0.57	560	120	4-M20x120	560-600
450	480.0	4.0	723823	20	0.54	588	120	4-M20x120	560-600
500	508.0	4.0	810732	20	0.51	624	122	4-M22x130	740-800
500	530.0	4.0	882473	20	0.49	650	122	4-M22x130	240-290
600	609.6	4.0	1167454	20	0.42	730	124	4-M22x140	560-600
600	630.0	4.0	1246898	20	0.41	755	124	4-M22x140	560-600
700	711.2	2.5	993147	20	0.77	840	150	4-M24x150	960-1050
800	812.8	2.5	1297171	20	0.68	950	150	4-M24x150	960-1050
900	914.4	2.5	1641732	20	0.60	1060	150	4-M24x160	960-1050
1000	1016.0	2.5	2026830	20	0.54	1165	170	4-M27x170	1420-1580
1050	1066.8	2.5	2234580	20	0.51	1216	170	4-M27x170	1420-1580
1100	1117.6	2.5	2452464	20	0.49	1268	170	4-M27x180	1420-1580
1150	1168.4	2.5	2680483	20	0.47	1320	170	4-M27x180	1420-1580
1200	1219.2	2.5	2918635	30	0.45	1375	258	4-M30x200	1920-2080

- This product is a forged steel coupling, and the pressure level can be customized according to the actual requirements of the customer.
- The dimensions of this structure refer to the dimensions after installation.
- The table indicates the installation torque for each specification of coupling, which ensures that the coupling is installed in place and achieves effective sealing. If the installation torque does not meet the requirements, it will result in unsuccessful coupling installation. Attention: Do not exceed the specified maximum torque value during installation, otherwise it may cause bolt fracture and ultimately affect the service life of the coupling.

# Sleeve type flexible coupling

## □ HN type flexible coupling

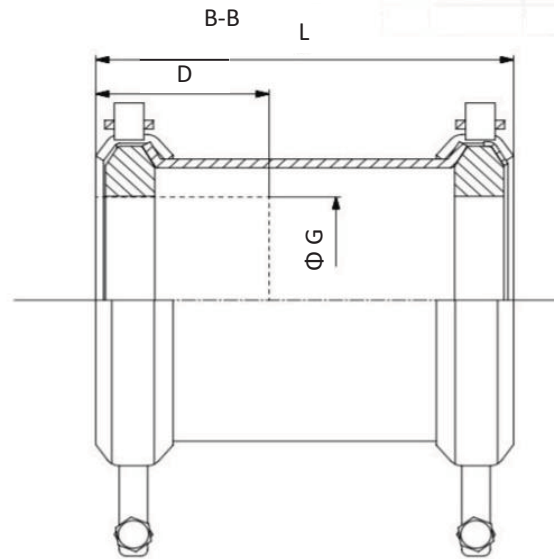
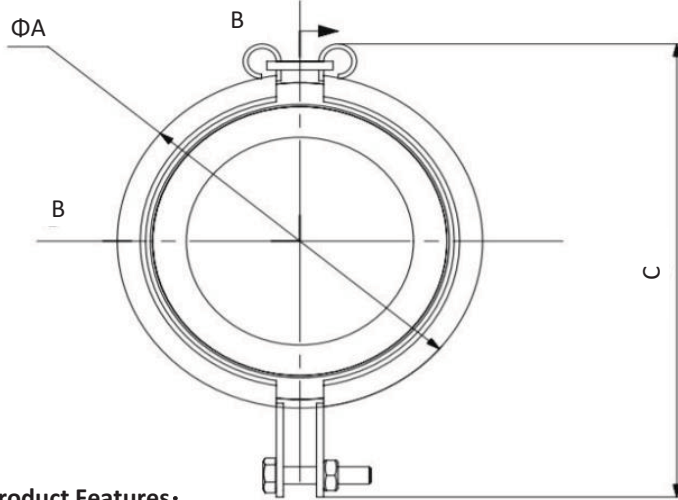

### Product Features:

- ◆ The sleeve type flexible joint installation is simple and convenient.
- ◆ No processing is required on the pipeline.
- ◆ The connection can be completed by inserting the locking nut into the joint of the pipeline.
- ◆ The sealing ring is made of Viton medium oil and oily air.
- ◆ Temperature -30 to 200 °C.

### Parameter Table:

No.	Size Type	Pipe OD.	ΦA	C	D	ΦG	L
1	HN-33.7	34	60	83	29-35	33.7	73
2	HN-38.0	38	64	92	30-39	38.0	81
3	HN-42.4	42	72	95	30-39	42.4	83
4	HN-48.3	48	77	100	30-41	48.3	89
5	HN-60.1	60	88	115	30-47	60.3	102
6	HN-75.0	75	122	154	40-62	75.0	135
7	HN-89.0	89	137	165	45-78	88.9	161
8	HN-100.0	102	157	179	45-	101.6	162

### Application Diagram:



# Grooved Rigid Coupling

## □ C8 type simple stainless steel coupling (upcoming)

### Describe:

Size: 2"-8" (DN50-200)

Maximum work pressure: 3.45 Mpa (500 psi)

Material: Standard configuration 304, or 316

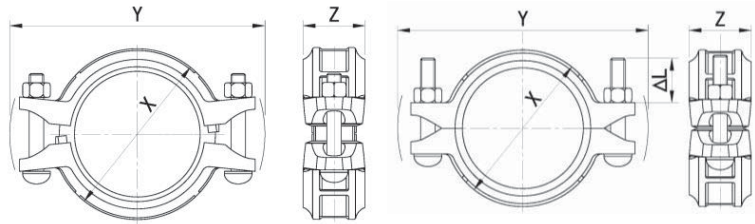

Original state of simple decoration

Status after installation completion

### Parameter Table:

Size		Max. Work Pressure	End Load	Pipe End Separation	Original state		Completion status				Bolt Size	Install Torque
					X	Y	X	Y	Z	ΔL		
in	mm	Mpa	N	mm	mm	mm	mm	mm	mm	mm	mm	N.m
2	60.3	3.45	9852	0-3.2	96	145	90	140	47	30	M10x60	40-60
2½	73.0	3.45	14440	0-3.2	110	160	106	155	48	30	M10x60	40-60
3OD	76.1	3.45	15692	0-3.2	113	163	107	159	48	30	M10x60	40-60
3	88.9	3.45	21415	0-3.2	125	176	119	172	48	30	M12x75	80-120
4¼OD	108.0	3.45	31605	0-6.4	145	196	139	192	51	32	M12x75	80-120
4	114.3	3.45	35400	0-6.4	151	202	145	198	51	32	M12x75	80-120
5¼OD	133.0	3.45	47931	0-6.4	174	230	168	225	52	35	M12x75	80-120
6¼OD	159.0	3.45	68502	0-6.4	196	270	190	265	53	40	M16x90	180-240
6	168.3	3.45	76750	0-6.4	205	279	199	274	53	40	M16x90	180-240
8	219.1	3.45	130075	0-6.4	256	330	250	325	63	40	M16x100	180-240

- For more detailed specifications, please consult Barico.
- The dimensions of this structure refer to the dimensions after installation.
- The table indicates the installation torque for each specification of coupling, which ensures that the coupling is installed in place and achieves effective sealing. If the installation torque does not meet the requirements, it will result in unsuccessful coupling installation. Attention: Do not exceed the specified maximum torque value during installation, otherwise it may cause bolt fracture and ultimately affect the service life of the coupling.

If you need a simple flexible groove coupling, please consult with Barico.

## Grooved welded short pipe

### □ C11 type Grooved short pipe

#### Describe :

Size:1"-18"(DN25-450)

Maximum work pressure:8.6Mpa(1250psi)

Material:Standard configuration 304, or 316, 316L and Duplex stainless steel.



#### Parameter Table:

size		L	Roll Groove Approx. Wt. Ea.	Cut Groove Approx. Wt. Ea.
in	mm	mm	kg	kg
1	33.7	40	0.063	0.106
1¼	42.4	40	0.081	0.136
1½	48.3	40	0.093	0.157
2½OD	57.0	40	0.110	0.187
2	60.3	40	0.117	0.198
2½	73.0	40	0.210	0.276
3OD	76.1	40	0.219	0.288
3	88.9	40	0.258	0.339
3½	101.6	40	0.295	0.482
4¼OD	108.0	40	0.314	0.514
4	114.3	40	0.322	0.546
5¼OD	133.0	40	0.390	0.639
5½OD	139.7	40	0.410	0.673
6¼OD	159.0	40	0.468	0.769
6½OD	165.1	40	0.486	0.804
8	219.1	50	0.810	1.467
10	273.0	50	1.178	2.002
12	323.9	50	1.401	2.382
14	355.6	65	2.254	3.912
16	406.4	65	2.899	4.804
18	457.2	65	3.265	5.764

- For larger and more detailed specifications, please consult with Barico.
- Please consult with Barico for parameters of high-performance grooved short pipes.
- For more pressure grade grooved short pipes, please consult with Barico.

## Groove Dimensions-standard groove

### □ Roll Groove

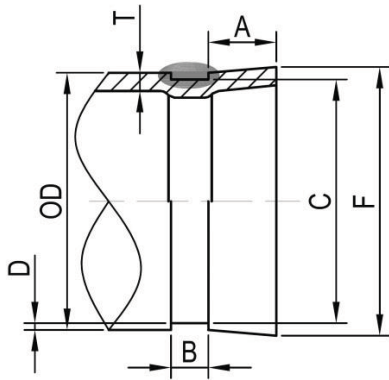

SIZE			Gasket Seat	Grv. Width	Grv.Dia.C		Grv. Depth	Min Wall	Max. Flare	
Nominal	OD	Tolerance		A	B	Std.	Tolerance	D(Re)	T	F
in.	mm	+ mm	-mm	±0.76mm	±0.76mm	mm	mm	mm	mm	Max.
1	33.7	0.41	0.68	15.88	7.14	30.23	-0.38	1.6	1.65	34.5
1-1/4	42.4	0.50	0.60	15.88	7.14	38.99	-0.38	1.6	1.65	45
1-1/2	48.3	0.48	0.52	15.88	7.14	45.09	-0.38	1.6	1.65	51.1
57.0mm	57.0	0.61	0.61	15.88	8.74	53.85	-0.38	1.6	1.65	59.7
2	60.3	0.61	0.61	15.88	8.74	57.15	-0.38	1.6	1.65	63
2-1/2	73.0	0.74	0.74	15.88	8.74	69.09	-0.46	1.98	2.11	75.7
76.1mm	76.1	0.76	0.76	15.88	8.74	72.26	-0.46	1.98	2.11	78.7
3	88.9	0.89	0.79	15.88	8.74	84.94	-0.46	1.98	2.11	91.4
3-1/2	101.6	1.02	0.79	15.88	8.74	97.38	-0.51	2.11	2.11	104.1
108.0mm	108.0	1.09	0.79	15.88	8.74	103.73	-0.51	2.11	2.11	110.5
4	114.3	1.14	0.79	15.88	8.74	110.08	-0.51	2.11	2.11	116.8
133.0mm	133.0	1.35	0.79	15.88	8.74	129.13	-0.51	2.11	2.77	135.9
139.7mm	139.7	1.42	0.79	15.88	8.74	135.48	-0.51	2.11	2.77	142.2
159.0mm	159.0	1.60	0.79	15.88	8.74	154.68	-0.56	2.16	2.77	161.3
165.1mm	165.1	1.60	0.79	15.88	8.74	160.90	-0.56	2.16	2.77	167.6
6	168.3	1.60	0.79	15.88	8.74	163.96	-0.56	2.16	2.77	170.9
200A	216.3	1.60	0.79	19.05	11.91	211.61	-0.64	2.34	2.77	220.7
8	219.1	1.60	0.79	19.05	11.91	214.40	-0.64	2.34	2.77	223.5
250A	267.4	1.60	0.79	19.05	11.91	262.60	-0.69	2.39	3.40	271.8
10	273.0	1.60	0.79	19.05	11.91	268.28	-0.69	2.39	3.40	277.4
300A	318.5	1.60	0.79	19.05	11.91	312.90	-0.76	2.77	3.96	322.8
12	323.9	1.60	0.79	19.05	11.91	318.29	-0.76	2.77	3.96	328.2
14	355.6	1.60	0.79	23.83	11.91	350.04	-0.76	2.77	3.96	359.7
350	377.0	1.60	0.79	23.83	11.91	371.44	-0.76	2.77	4.19	381.1
16	406.4	1.60	0.79	23.83	11.91	400.84	-0.76	2.77	4.19	410.5
400	426.0	1.60	0.79	23.83	11.91	420.44	-0.76	2.77	4.19	430.1
18	457.2	1.60	0.79	25.40	11.91	451.64	-0.76	2.77	4.19	461.3
450	480.0	1.60	0.79	25.40	11.91	474.44	-0.76	2.77	4.19	484.1
20	508.0	1.60	0.79	25.40	11.91	502.44	-0.76	2.77	4.78	512.1
500	530.0	1.60	0.79	25.40	11.91	524.44	-0.76	2.77	4.78	535.1

Explanation: For larger and more groove parameters, please consult with Barico.

## Groove Dimensions-standard groove

### □ Cut Groove

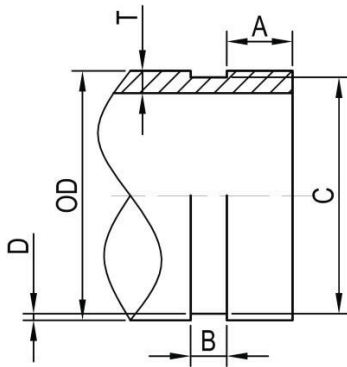

SIZE			Gasket Seat	Grv.Width	Grv.Dia. C		Grv.Depth	Min Wall	
Nominal	OD	Tolerance		A	B	Std.	Tolerance	D (Reference)	T
in.	mm	+ mm	- mm	±0.76mm	±0.76mm	mm	mm	mm	mm
3/4	26.9	0.25	0.25	15.88	7.95	23.83	-0.38	1.42	3.0
1	33.7	0.41	0.68	15.88	7.95	30.23	-0.38	1.60	3.3
1-1/4	42.4	0.50	0.60	15.88	7.95	38.99	-0.38	1.60	3.5
1-1/2	48.3	0.48	0.52	15.88	7.95	45.09	-0.38	1.60	3.6
57.0mm	57.0	0.61	0.61	15.88	7.95	53.85	-0.38	1.60	3.6
2	60.3	0.61	0.61	15.88	7.95	57.15	-0.38	1.60	3.6
2-1/2	73.0	0.74	0.74	15.88	7.95	69.09	-0.46	1.98	4.0
76.1mm	76.1	0.76	0.76	15.88	7.95	72.26	-0.46	1.98	4.0
3	88.9	0.89	0.79	15.88	7.95	84.94	-0.46	1.98	4.5
3-1/2	101.6	1.02	0.79	15.88	7.95	97.38	-0.51	2.11	4.5
108.0mm	108.0	1.09	0.79	15.88	9.53	103.73	-0.51	2.11	5.0
4	114.3	1.14	0.79	15.88	9.53	110.08	-0.51	2.11	5.0
133.0mm	133.0	1.35	0.79	15.88	9.53	129.13	-0.51	2.11	5.0
139.7mm	139.7	1.42	0.79	15.88	9.53	135.48	-0.51	2.11	5.0
159.0mm	159.0	1.60	0.79	15.88	9.53	154.68	-0.56	2.16	5.4
165.1mm	165.1	1.60	0.79	15.88	9.53	160.9	-0.56	2.16	5.4
6	168.3	1.60	0.79	15.88	9.53	163.96	-0.56	2.16	5.4
200A	216.3	1.60	0.79	19.05	11.13	211.61	-0.64	2.34	5.4
8	219.1	1.60	0.79	19.05	11.13	214.4	-0.64	2.34	5.4
250A	267.4	1.60	0.79	19.05	12.70	262.6	-0.69	2.39	6.3
10	273.0	1.60	0.79	19.05	12.70	268.28	-0.69	2.39	6.3

## Groove Dimensions-standard groove

### □ Cut Groove (continuous)

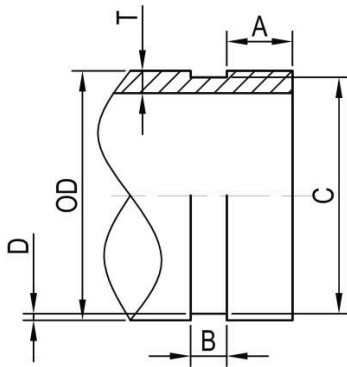

SIZE			Gasket Seat	Grv. Width	Grv. Dia. C		Grv. Depth	Min Wall	
Nominal	OD	Tolerance		A	B	Std.	Tolerance	D (Reference)	T
in.	mm	+ mm	- mm	±0.76mm	±0.76mm	mm	mm	mm	mm
304.8mm	304.8	1.60	0.79	19.05	12.70	299.24	-0.76	2.77	7.09
300A	318.5	1.60	0.79	19.05	12.70	312.90	-0.76	2.77	7.09
12	323.9	1.60	0.79	19.05	12.70	318.29	-0.76	2.77	7.09
14	355.6	1.60	0.79	23.83	12.70	350.04	-0.76	2.77	7.14
377mm	377.0	1.60	0.79	23.83	12.70	371.44	-0.76	2.77	7.14
15	381.0	1.60	0.79	23.83	12.70	375.44	-0.76	2.77	7.92
16	406.4	1.60	0.79	23.83	12.70	400.84	-0.76	2.77	7.92
426mm	426.0	1.60	0.79	23.83	12.70	420.44	-0.76	2.77	7.92
18	457.2	1.60	0.79	25.40	12.70	451.64	-0.76	2.77	7.92
480mm	480.0	1.60	0.79	25.40	12.70	474.44	-0.76	2.77	7.92
20	508.0	1.60	0.79	25.40	12.70	502.44	-0.76	2.77	7.92
530mm	530.0	1.60	0.79	25.40	12.70	524.44	-0.76	2.77	7.92
22	558.8	1.60	0.79	25.40	14.30	550.06	-0.76	4.37	9.53
24	610.0	1.60	0.79	25.40	14.30	600.86	-0.76	4.73	9.53
630mm	630.0	1.60	0.79	25.40	14.30	620.86	-0.76	4.37	9.53
26	660.4	2.36	0.79	44.45	15.88	647.70	-1.60	6.35	15.88
28	711.2	2.36	0.79	44.45	15.88	698.50	-1.60	6.35	15.88
30	762.0	2.36	0.79	44.45	15.88	749.30	-1.60	6.35	15.88
32	812.8	2.36	0.79	44.45	15.88	800.10	-1.60	6.35	15.88
34	863.4	2.36	0.79	44.45	15.88	850.70	-1.60	6.35	15.88
36	914.4	2.36	0.79	44.45	15.88	901.70	-1.60	6.35	15.88
38	965.2	2.36	0.79	44.45	15.88	952.50	-1.60	6.35	15.88
40	1016.0	2.36	0.79	50.80	15.88	1003.30	-1.60	6.35	15.88
42	1066.8	2.36	0.79	50.80	15.88	1054.10	-1.60	6.35	15.88

Explanation: For larger and more groove parameters, please consult with Barico.

## Groove Dimensions-High performance groove

### □ Cut Groove

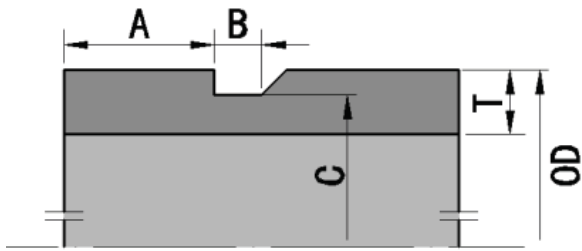

SIZE				Gasket Seat	Grv. Width	Grv. Dia. C		Min Wall
Nominal	OD	Tolerance		A	B	Std.	Tolerance	T
in.	mm	+ mm	- mm	$\pm 0.76\text{mm}$	$\pm 0.76\text{mm}$	mm	mm	mm
14	355.6	1.60	0.79	38.1	11.6	342.9	-1.10	12.0
377mm	377.0	1.60	0.79	38.1	11.6	364.3	-1.10	12.0
16	406.4	1.60	0.79	38.1	11.6	393.7	-1.10	12.0
426mm	426.0	1.60	0.79	38.1	11.6	413.3	-1.10	12.0
18	457.2	1.60	0.79	38.1	11.6	444.5	-1.10	12.0
480mm	480.0	1.60	0.79	38.1	11.6	467.3	-1.10	12.0
20	508.0	1.60	0.79	38.1	11.6	495.3	-1.10	13.0
530mm	530.0	1.60	0.79	38.1	11.6	517.3	-1.10	13.0
22	558.8	1.60	0.79	38.1	11.6	546.1	-1.10	13.0
24	610.0	1.60	0.79	38.1	11.6	596.9	-1.10	13.0
630mm	630.0	1.60	0.79	38.1	11.6	617.3	-1.10	13.0
26	660.4	2.36	0.79	44.5	13.6	645.9	-1.50	15.0
28	711.2	2.36	0.79	44.5	13.6	696.7	-1.50	15.0
720mm	720.0	2.36	0.79	44.5	13.6	705.5	-1.50	15.0
30	762.0	2.36	0.79	44.5	13.6	747.5	-1.50	15.0
32	812.8	2.36	0.79	44.5	13.6	798.3	-1.50	15.0
34	863.4	2.36	0.79	44.5	13.6	848.9	-1.50	15.0
36	914.4	2.36	0.79	44.5	13.6	899.9	-1.50	15.0
38	965.2	2.36	0.79	44.5	13.6	950.7	-1.50	15.0
40	1016.0	2.36	0.79	50.80	14.3	1000.1	-1.50	16.0
42	1066.8	2.36	0.79	50.80	14.3	1050.9	-1.50	16.0
44	1117.6	2.36	0.79	50.80	14.3	1101.7	-1.50	16.0
46	1168.4	2.36	0.79	50.80	14.3	1152.5	-1.50	16.0
48	1219.2	2.36	0.79	50.80	14.3	1203.3	-1.50	16.0

Explanation: For larger and more groove parameters, please consult with Barico.



Shanghai Barico Industrial Co., Ltd

[www.baricoinc.com](http://www.baricoinc.com)

Contact person: Manager Young

Telephone :0086-182-2125-7565

Address: Building 1, No. 377, Nanqiao Road, Nanqiao Town, Fengxian District, Shanghai

Version1.0