

Style HG01 | Swivel Ring Hanger



Size Range: 1/2"- 8" | 15-200mm

Material: Carbon steel

Approvals: FM approval /UL listed

Finish: Plan or Zinc Plated(Hot-Dip Galvanized optional)

Service: Recommended for suspension of stationary pipe or conduit.

Features:

- Threads are countersunk so that they cannot become burred or damaged.
- Knurled swivel nut provides vertical adjustment after piping is in place.
- Captured swivel nut will not fall off.



Technical Data

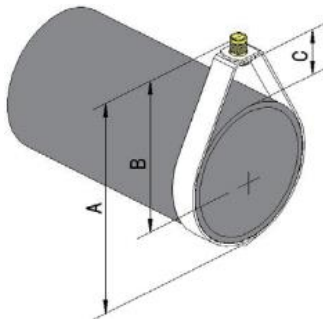

Pipe Size	Rod Size	A	B	C	Width	Max Load	Approx. Wt. Ea.
In/mm	In/mm	In/mm	In/mm	In/mm	In/mm	Lbf/N	Lbs./kg
1/2	3/8	2.56	2.13	1.22	0.86	300	0.09
15	M10	65.0	54.0	31.0	22.0	1335	0.04
3/4	3/8	2.83	2.26	1.14	0.86	300	0.11
20	M10	72.0	57.5	29.0	22.0	1335	0.05
1	3/8	3.07	2.36	0.98	0.86	300	0.13
25	M10	78.0	60.0	25.0	22.0	1335	0.06
1 1/4	3/8	3.46	2.58	0.94	0.86	300	0.13
32	M10	88.0	65.5	24.0	22.0	1335	0.06
1 1/2	3/8	3.74	2.76	0.98	0.86	300	0.15
40	M10	95.0	70.0	25.0	22.0	1335	0.07
2	3/8	4.13	2.89	1.30	0.86	300	0.18
50	M10	105.0	73.5	33.0	22.0	1335	0.08
2 1/2	3/8	4.92	3.37	1.18	0.86	525	0.20
65	M10	125.0	85.5	30.0	22.0	2335	0.09
3	3/8	5.51	3.70	1.22	0.86	525	0.22
80	M10	140.0	94.0	31.0	22.0	2335	0.10
4	3/8	6.81	4.47	1.57	0.86	650	0.37
100	M10	173.0	113.5	40.0	22.0	2893	0.17
5	1/2	8.23	5.35	1.26	1.26	1000	0.73
125	M12	209.0	136.0	32.0	32.0	4450	0.33
6	1/2	9.80	6.38	2.09	1.26	1000	0.84
150	M12	249.0	162.0	53.0	32.0	4450	0.38
8	1/2	12.17	7.76	2.40	1.57	1000	1.26
200	M12	309.0	197.0	61.0	40.0	4450	0.57